

ISOMETRIC

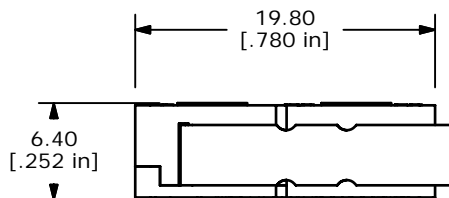

O.P. (MM)	P.T. (MM)
9.1 ±0.8	3.8 MAX

O.P. = OPERATING POINT
P.T. = PRE-TRAVEL

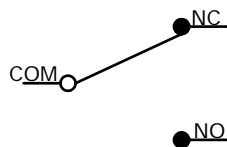

CIRCUIT: SPDT

- NOTES:
1. ALL DIMENSIONS IN MM [INCH]
 2. GENERAL TOLERANCE: X.X=±0.4
X.XX=±0.25
 3. RATING: 5A @125/250VAC UL, CUL, VDE APPROVED
 - ▲4. OPERATING FORCE: 025±12 GRAMS
 5. OPERATING TEMP: -25°C TO 85°C
 6. ELECTRICAL LIFE: 50,000 CYCLES MIN.
 7. MECHANICAL LIFE: 1,000,000 CYCLES TYP.
 8. INSULATION RESISTANCE: 100 MEGA-OHMS
 9. DIELECTRIC STRENGTH: 1000VAC 1 MINUTE (INITIAL VALUE)
 10. CONTACT RESISTANCE: 100 MILLI-OHMS MAX.
 11. ▲ DENOTES CRITICAL PARAMETER.
 12. 2002/95/EC (ROHS) COMPLIANT

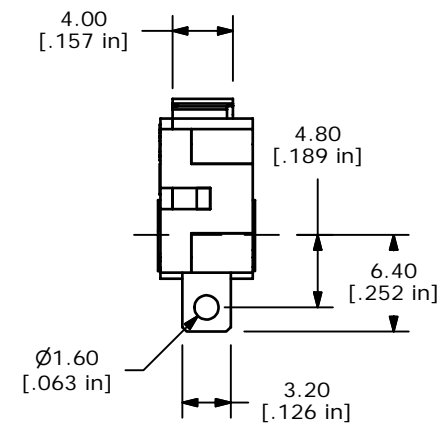
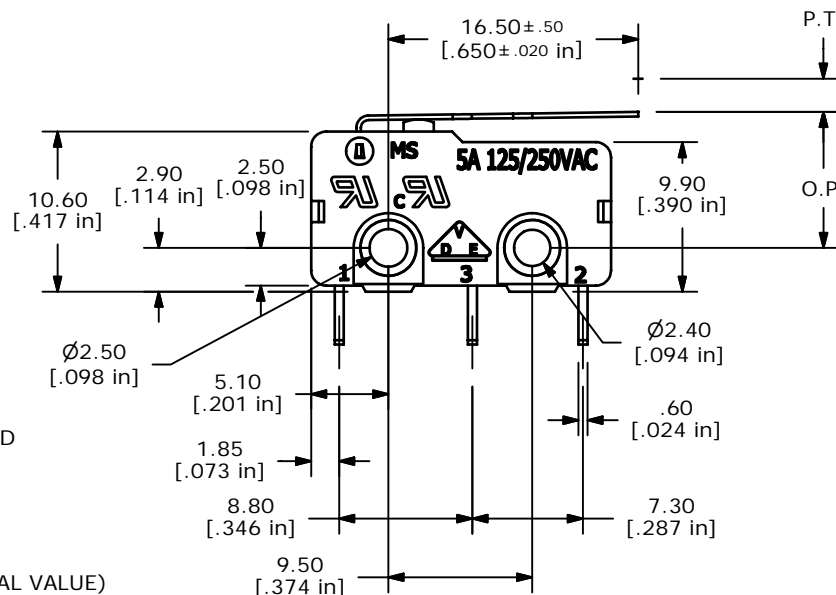

TITLE MS0850502F025S1A

A	17287	RELEASED FOR PRODUCTION	5/15/07	TN
REV	PCR NO	DESCRIPTION	DATE	BY

THE INFORMATION CONTAINED IN THIS DOCUMENT IS PROPRIETARY TO E-SWITCH AND IS NOT TO BE COPIED OR TRANSFERRED

SCALE	DATE	DR	DWG	REV
2:1	5/15/2007	TN	Q970078	A