

1) FIGURE OF INSERTION

HORIZONTALLY ○

DF57H-4S-1.2C

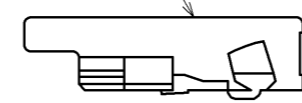

DIAGONAL ×

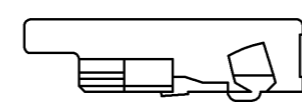

DF57-***SCF

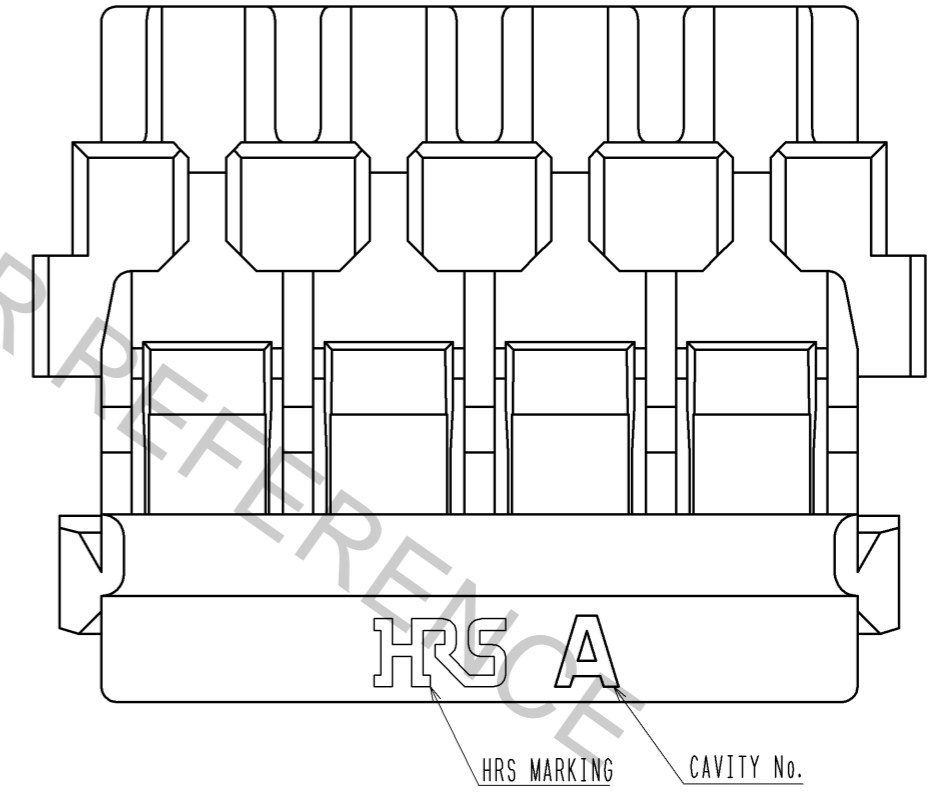
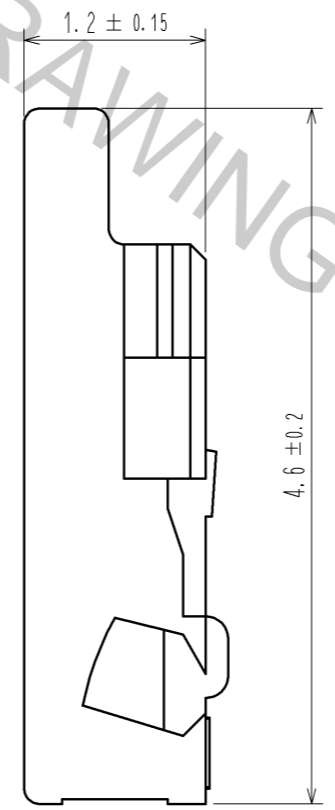
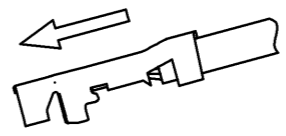
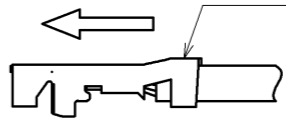

NOTE 1) AVOID ANGLED INSERTION OF CRIMP CONTACT(DF57-***SCF) TO MAINTAIN PERFORMANCE RELIABILITY.

部番	材質	処 理 , 備 考	1	PBT	UL94V-0, NATURAL(WHITE)
UNITS mm		SCALE 20:1	△の数	訂 正 記 事	設 計
HRS HIROSE ELECTRIC CO., LTD.	承認 : KI. AKIYAMA 検 査 : HK. UMEHARA 設 計 : TS. KUMAZAWA 製 図 : TS. KUMAZAWA	12.03.19 12.03.19 12.03.19 12.03.19	図番 : 製品名 : 製品コード :	EDC3-343901-00 DF57H-4S-1.2C CL666-0101-9-00	
			年月日	検 査	年 月 日

DF57 Series Mating / Unmating Operation Instruction

Mating

① By positioning the convexity of the socket sides to the header concavity, align the centers of the socket and the header in pitch direction.

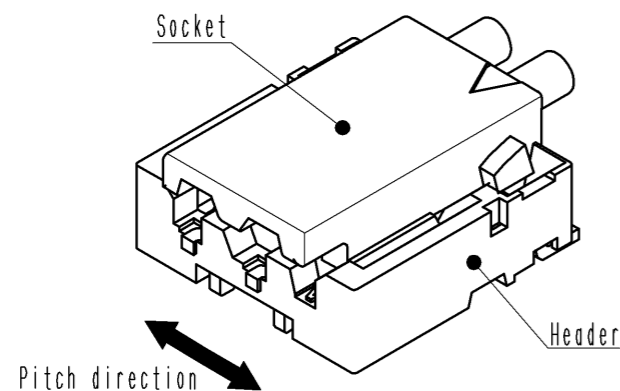

② Slightly press the socket down at cable side to tilted angle.

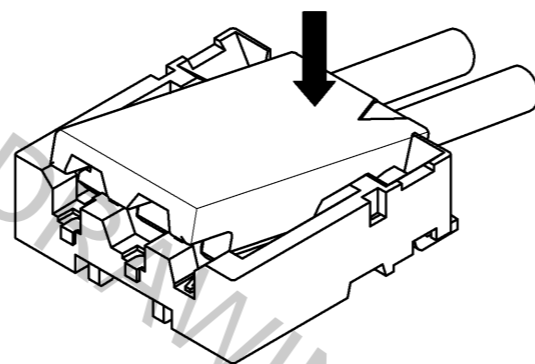

③ Press down at the lever side with stabilizing the cable side to insert. Mating completes.

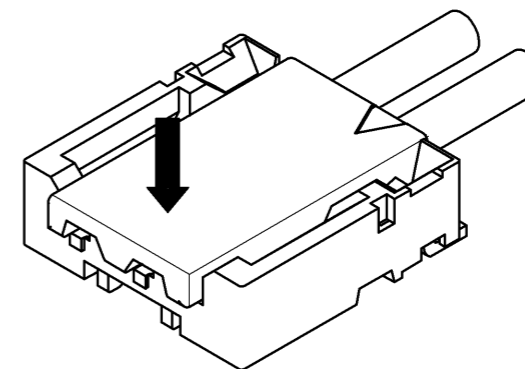

Unmating

① Hook the lever with finger nail.

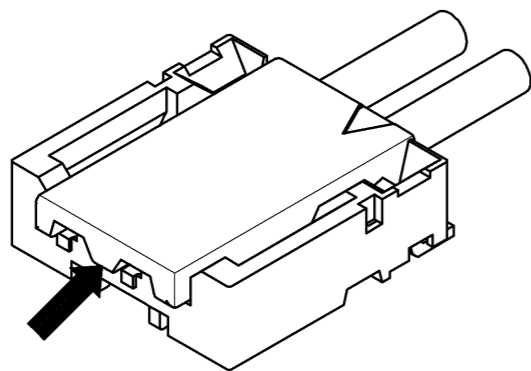

② Lift up to the upper direction and friction lock is released.

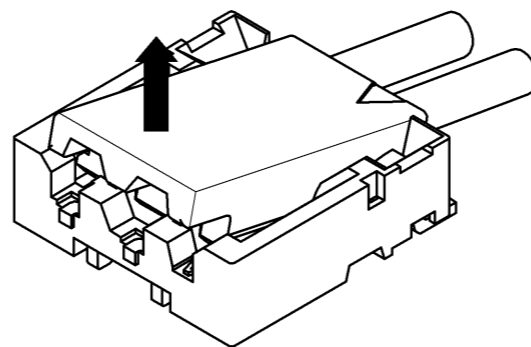

③ Lift up to the upper direction and positive lock is released. Removal completes.

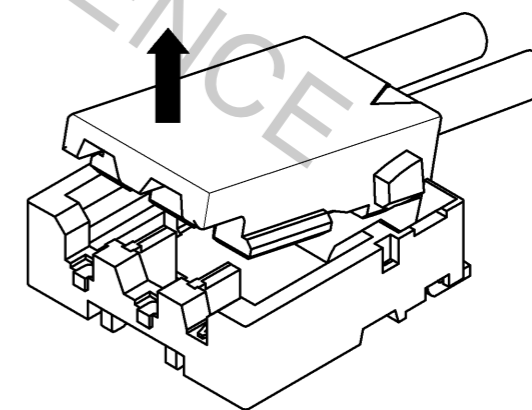

HRS	DRAWING NO.	EDC3-343901-00	2/2
	PART NO.	DF57H-4S-1.2C	
	CODE NO.	CL666-0101-9-00	