

THIS DRAWING IS UNPUBLISHED. RELEASED FOR PUBLICATION  
 © COPYRIGHT BY TYCO ELECTRONICS CORPORATION. ALL RIGHTS RESERVED.

LOC	DIST	REVISIONS			
P	LTR	DESCRIPTION	DATE	DWN	APVD
	B1	REVISED PER ECO-08-019381	07AUG08	HMR	MW

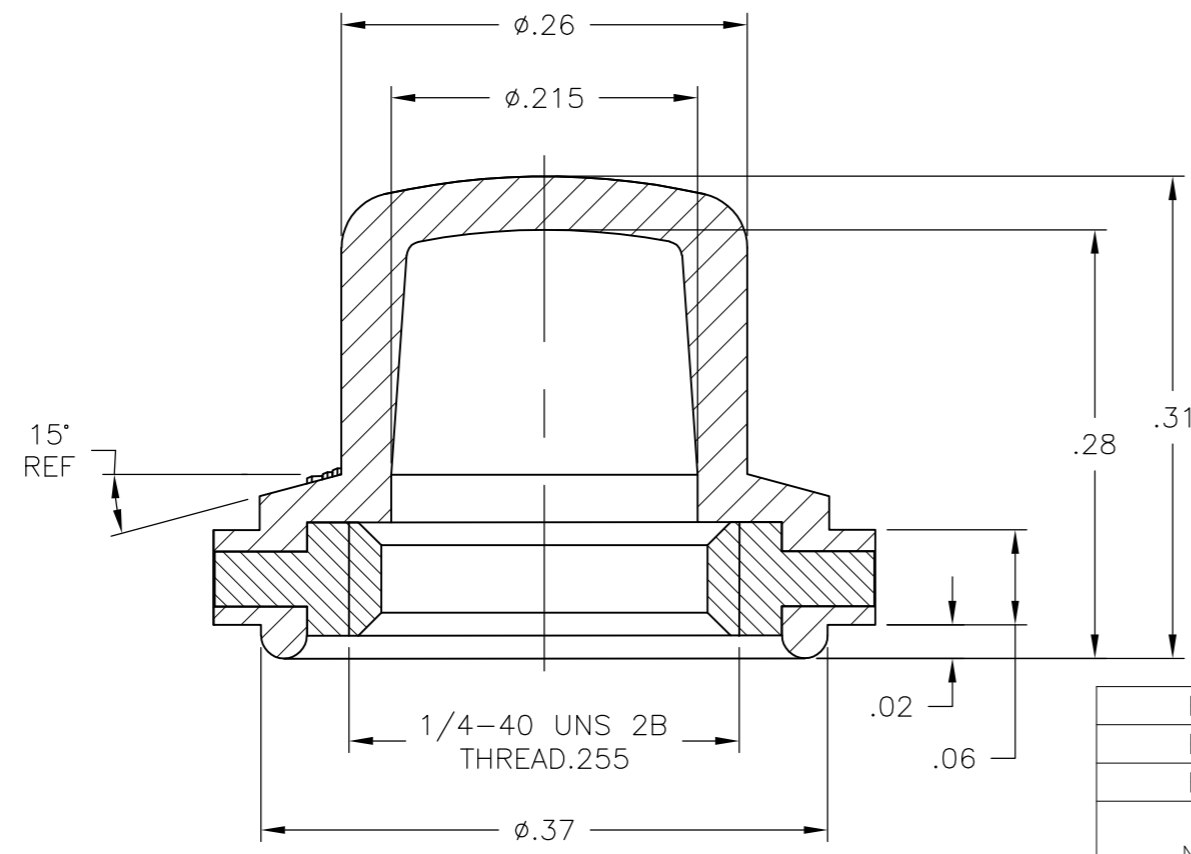
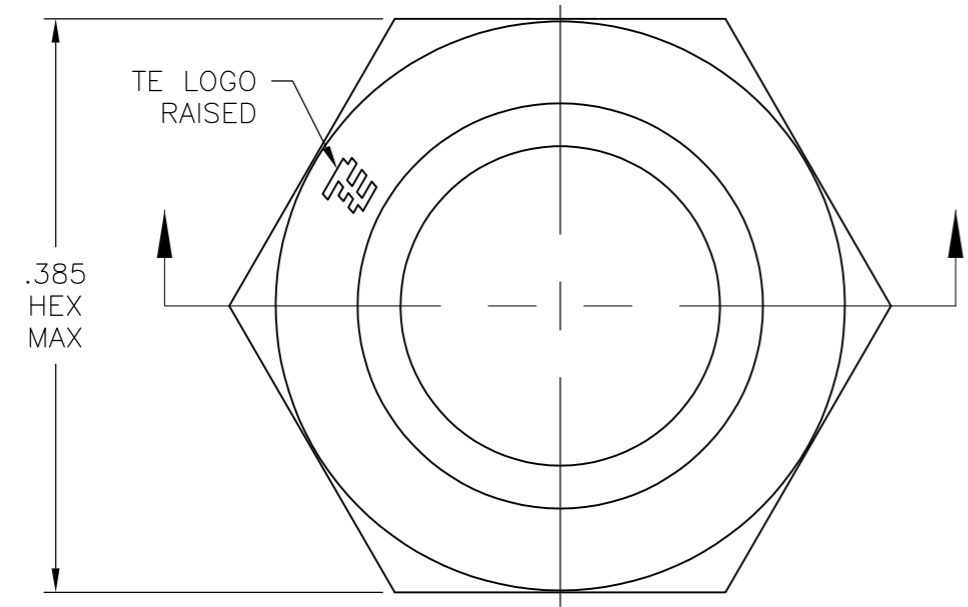

- SOME DIMENSIONS MAY VARY DUE TO DIFFERENT COMPOUND SHRINKAGE FACTOR.
- MINOR FLASH ACCEPTABLE ON INSERT THREAD.
- BLACK FINISH/NICKEL PLATING ON INSIDE THREADS REMOVED DUE TO MODEL PROCESS PERMITTED.
- RUBBER TO METAL BOND MUST MEET OR EXCEED THE TEAR STRENGTH OF RUBBER.
- RUBBER OVERLAY PERMISSIBLE OVER HEX FLATS AS SHOWN IN THE DRAWING.
- COMPONENTS MUST COMPLY WITH THE EUROPEAN DIRECTIVE 2002/95/EC ON RESTRICTION OF THE USE OF CERTAIN HAZARDOUS SUBSTANCES IN ELECTRICAL AND ELECTRONIC EQUIPMENT (ROHS DIRECTIVE).

ALCO NUMBER	RUBBER BOOT MATERIAL	HEX NUT MATERIAL	PART NUMBER
BPA1440804	SILICONE, COLOR GRAY	BRASS, NICKEL PLATE PER QQ-N-290	1825604-3
BPA1440204	SILICONE, COLOR RED	BRASS, NICKEL PLATE PER QQ-N-290	1825604-2
BPA1440004	SILICONE, COLOR BLACK	BRASS, BLACK OXIDE PER MIL-F-495	1825604-1

THIS DRAWING IS A CONTROLLED DOCUMENT.		DWN S SCHLEGEL 03MAR2008	Tyco Electronics Corporation Harrisburg, PA 17105-3608			
DIMENSIONS: INCHES 		CHK M WILBOURN 3/3/08	NAME MINIATURE 1/4-40 PUSHBUTTON BOOT SEAL			
TOLERANCES UNLESS OTHERWISE SPECIFIED: 0 PLC ± - 1 PLC ± - 2 PLC ± .01 3 PLC ± .005 4 PLC ± - ANGLES ± 5'		APVD M WILBOURN 3/3/08				
MATERIAL		PRODUCT SPEC	SIZE	CAGE CODE	DRAWING NO	RESTRICTED TO
-		FINISH	A300779		C-1825604	-
CUSTOMER DRAWING			SCALE	SHEET	REV	
			8:1	1 OF 1	B1	