

LOC		DIST		REV		ZONE		LTR		REVISIONS		DATE	APPD
GP	00	R	F					H			DESCRIPTION		
											REVISED PER EC 0513-0012-03	08MAY03	JG

- CONNECTOR MATES WITH ANY 25 POS. PLUG IN AMPLIMITE SERIES & COMPLIES WITH AMP SPEC. 108-40,005 WHERE APPLICABLE.
- FLAME RETARDANT 94V-0 RATED THERMOPLASTIC; COLOR: BLACK.
- STEEL PER ASTM A109.
- PHOS. BRONZE PER QQ-B-750.
- SCREWLOCKS: STEEL PER ASTM A109, WASHERS: STEEL PER ASTM A108.
- TIN PLATING PER MIL-T-10727, ZINC PLATING PER ASTM B633, TYPE III; CLASS SC1; CLEAR CHROMATE, GOLD PLATING PER MIL-G-45204, NICKEL PLATING PER QQ-N-290.
- TIN PLATED.
- ZINC PLATED.
- GOLD FLASH FOR A LENGTH OF .100 MINIMUM FROM MATING END, .000100 MINIMUM TIN-LEAD ON OPPOSITE END, BOTH OVER .000050 MINIMUM NICKEL.
- .000030 MINIMUM GOLD FOR A LENGTH OF .100 MINIMUM FROM MATING END, .000100 MINIMUM TIN-LEAD ON OPPOSITE END, BOTH OVER .000050 MINIMUM NICKEL.
- LOCK WASHERS ARE FOR -1, -2 & -4, PLAIN WASHERS ARE FOR -1 & -2.

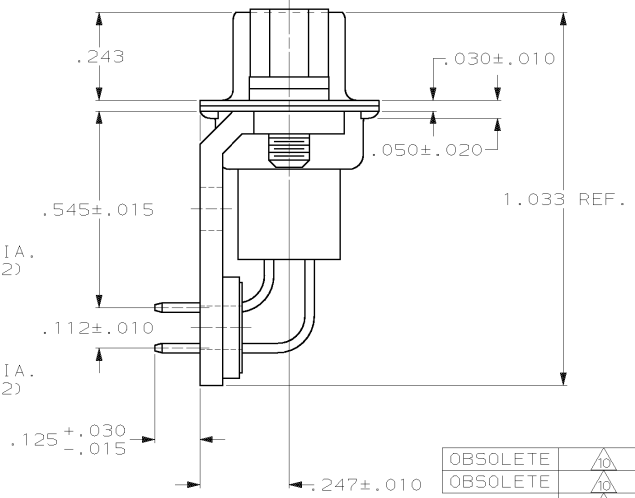

OBSOLETE	10	745536-4
OBSOLETE	10	745536-3
OBSOLETE	10	745536-2
OBSOLETE	10	745536-1
	CONTACT FINISH	PART NO

DO NOT SCALE PRINT. UNLESS SPECIFIED DIMENSIONS IN INCHES TOLERANCES ON: 2 PLC DEC ± - 3 PLC DEC ± .005 ANGLES ± 2°	DR 12-9-83 J. GERACE CHK 12-9-83 J. GERACE APPD 2-7-84 P. SWEIGARD APPD 2-7-84 J. ASSINI	AMP Incorporated Harrisburg, PA 17105-3608	NAME	
MATERIAL MOLDED PARTS: Δ SHELLS & BRACKETS: Δ CONTACTS: Δ HARDWARE: Δ	PRODUCT SPEC -		RECEPTACLE ASSEMBLY, SIZE 3, 25 POS., RIGHT ANGLE, .545 SERIES, .025 SQ. POSTS, W/ SCREWLOCKS, AMPLIMITE™ HDP	
FINISH SHELLS & BRACKETS: Δ CONTACTS: SEE TABLE HARDWARE: Δ	APPLICATION SPEC -	SIZE	CAGE CODE	DRAWING NO
	WEIGHT -	C	00779	C-745536
		SCALE	NTS	SHEET 1 OF 1

THIS DRAWING IS A CONTROLLED DOCUMENT FOR AMP INCORPORATED. IT IS SUBJECT TO CHANGE AND THE CONTROLLING ENGINEERING ORGANIZATION SHOULD BE CONTACTED FOR THE LATEST REVISION.