

THIS DRAWING IS UNPUBLISHED. RELEASED FOR PUBLICATION, 19 .
 © COPYRIGHT 19 BY AMP INCORPORATED. ALL INTERNATIONAL RIGHTS RESERVED.

| LOC | DIST | P | F | ZONE | LTR | REVISIONS | DATE | APPD |
|-----|------|---|---|------|-----|----------------------|---------|-------|
| AF | 50 | | | | C | REV PER 0710-0165-95 | 5/12/95 | JR/NN |

IDENTIFICATION NUMBER 4 FOR MAGNET WIRE RANGE

- ① SLOT ACCEPTS 0.18-0.23mm DIA [#33-#31]AWG COPPER MAGNET WIRE
- ② 0.00203-0.00635 [.000080-.000250] TIN PLATE PER MIL-T-10727 OVER 0.00254 [.000100] MIN COPPER UNDERPLATE PER MIL-C-14550.

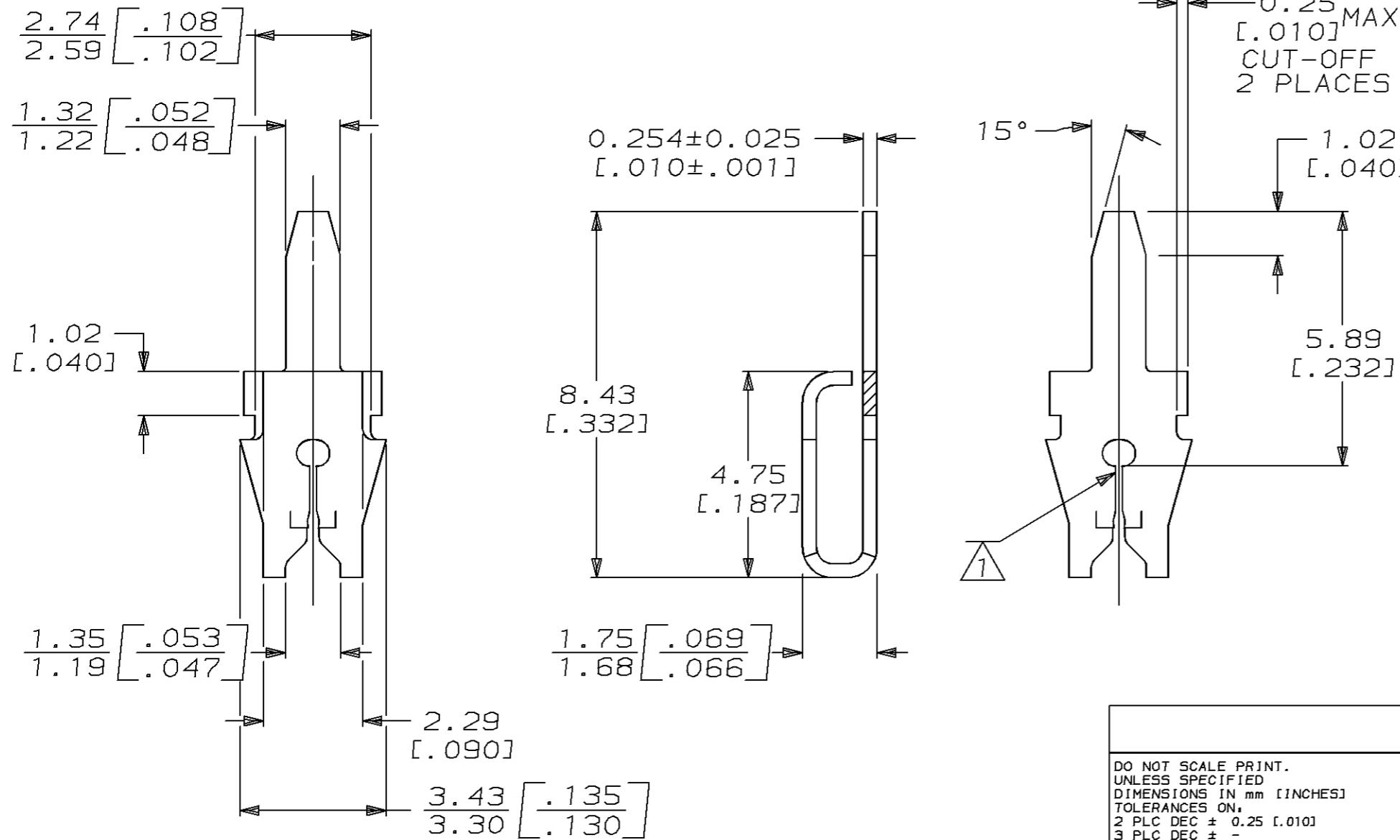

THIS DRAWING IS A CONTROLLED DOCUMENT FOR AMP INCORPORATED. IT IS SUBJECT TO CHANGE AND THE CONTROLLING ENGINEERING ORGANIZATION SHOULD BE CONTACTED FOR THE LATEST REVISION.

| | | | |
|-----------------------------------------------------------------------------------------------------------------------------------------|----------------------------------|-----------------------------------------------------|----------------------------------------------------------|
| DO NOT SCALE PRINT. UNLESS SPECIFIED DIMENSIONS IN mm [INCHES] TOLERANCES ON: 2 PLC DEC ± 0.25 [.010] 3 PLC DEC ± - ANGLES ± - | | DR 12/17/93 PHILLIP M FORTNEY | AMP AMP Incorporated Harrisburg, PA 17105-3608 |
| MATERIAL H04 BRASS | CHK 12/17/93 MICHAEL S FEHER | NAME TERMINAL, POSTED, LOOSE PIECE, MAG-MATE™ | |
| FINISH ② | APPD 12/17/93 NELSON E NEFF | SIZE B | CAGE CODE 00779 |
| | APPD 12/17/93 TERRY L SHUTTER | DRAWING NO C-62934 | |
| | PRODUCT SPEC 108-2012 | SCALE 8:1 | SHEET 1 OF 1 |
| | APPLICATION SPEC 114-2069 | PART NO 62934-1 | |
| | WEIGHT - | | |