

NOTES:

1. MATERIAL: POLYESTER (PBT), 7.5% GLASS FILLED, UL 94V-0. COLOR: BLACK
2. FINISH: NONE
3. PRODUCT SPEC.: PS-43510-002.
4. ALL DIMENSIONS SHOWN FOR REFERENCE ONLY.
5. PART TO BE USED WITH PODS SHOWN IN CHART. SEE SHEET 2 FOR ASSEMBLY INFORMATION.
6. PODS MAY BE PLACED IN ANY POSITION DESIRED.
7. PART MATES WITH 43838-0*** PLUG SHROUD, 44040-0*** VERTICAL HEADER SHROUD AND 44041-0*** RIGHT ANGLE HEADER SHROUD.
8. SEE SHEET 2 FOR APPLICATION NOTES.

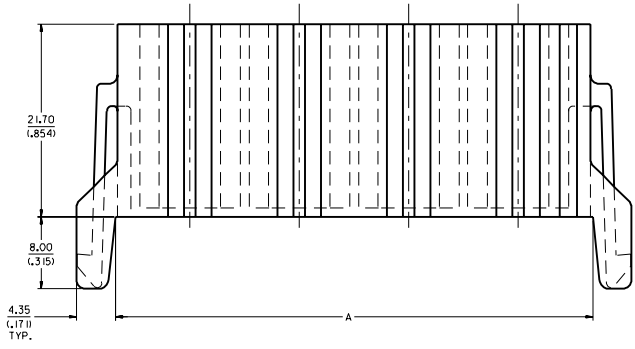

SEE NOTE 8

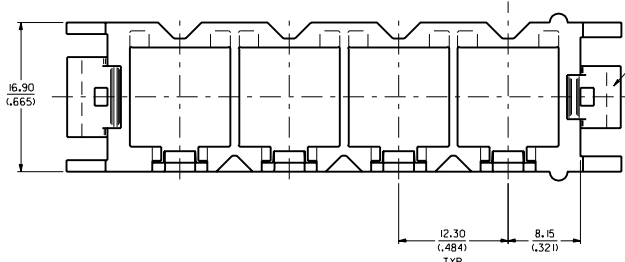
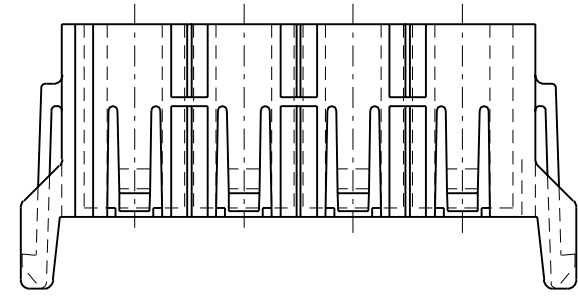
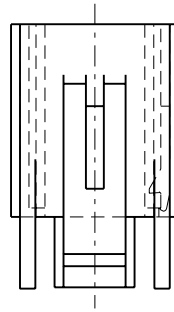

LATCHES ARE KEYED TO PREVENT IMPROPER MATING.

43516-0001	BLIND-MATE POD
43512-0001	6 CIRCUIT MICRO-FIT RECEPTACLE
43511-0001	4 CIRCUIT MINI-FIT JR. RECEPTACLE
43510-0001	1 CIRCUIT MINI-FIT SR. RECEPTACLE

MATERIAL NO.	DESCRIPTION
AVAILABLE PODS	

MATERIAL NO.	POSITIONS	DIM. "A"
43838-0601	6	78.30 (3,083)
43838-0501	5	66.00 (2,598)
43838-0401	4	53.70 (2,114)
43838-0301	3	41.40 (1,630)
43838-0201	2	29.10 (1,146)

2	A2
1	A2

REV. NOTES EC NO. UCR1999-0712 DRW/POL/GAR 990422 CHM/COMERC1 990426 APPR/COMERC1 990426	QUALITY SYMBOLS MAJOR \blacktriangledown \pm CRITICAL ∇ \pm	GENERAL TOLERANCES: (UNLESS SPECIFIED) SCALE 4 : 1 <input checked="" type="checkbox"/> mm <input type="checkbox"/> INCH	DESIGN UNITS <input checked="" type="checkbox"/> mm <input type="checkbox"/> INCH	DRAWN BY & DATE COMERC1 97/10/06 CHECKED BY & DATE COMERC1 97/10/06 APPROVED BY & DATE FRY 97/10/10	TITLE: RECEPTACLE SHROUD, 12.3 mm (1.484) PITCH, COMPRODE SYSTEM	MATERIAL NO. 4383803.DGN	MATERIAL NO. SD-43838-002	DRAWING NO. SD-43838-002	SHEET NO. 1 OF 2
	THIS DRAWING CONTAINS INFORMATION THAT IS PROPRIETARY TO MOLEX INCORPORATED AND SHOULD NOT BE USED WITHOUT WRITTEN PERMISSION.								
	INCORPORATED AND SHOULD NOT BE USED WITHOUT WRITTEN PERMISSION.								
	INCORPORATED AND SHOULD NOT BE USED WITHOUT WRITTEN PERMISSION.								

43838

APPLICATION NOTES:

1. PLACE THE HIGH CURRENT MINI-FIT SR. PODS IN THE OUTER POSITIONS OF THE SHROUD TO MAXIMIZE CURRENT CARRYING CAPABILITY.
2. IF MORE THAN ONE MINI-FIT SR. POD IS USED, PLACE THEM AS FAR APART AS POSSIBLE IN THE SHROUD TO MAXIMIZE CURRENT CARRYING CAPABILITY.
3. REFER TO THE INDIVIDUAL PRODUCT'S PRODUCT SPECIFICATION FOR DETAILED PERFORMANCE CHARACTERISTICS OF EACH. (MINI-FIT JR., MINI-FIT SR., MICRO-FIT 3.0, ETC.)
4. THE SHROUD PROVIDES SYSTEM POLARIZATION. PODS MUST NEVER BE APPLIED WITHOUT THE USE OF THE SHROUD. 'MALE' AND 'FEMALE' PODS CAN BE INSERTED INTO EITHER SHROUD FOR ADDITIONAL CONNECTOR POLARIZATION. WHEN MULTIPLE COMPODRE SYSTEMS ARE USED IN A SINGLE APPLICATION, THE PODS MAY BE POSITIONED TO PROVIDE FOOLPROOF HARNESS TO HARNESS POLARIZATION.
5. 'PIC TAIL' OR HARNESS PODS CAN BE INSERTED INTO RIGHT ANGLE HEADER SHROUDS WHERE NECESSARY.
6. TO OBTAIN THE LOWEST POSSIBLE MATING FORCES OF A FULLY LOADED SHROUD, THE TERMINALS MUST BE ALLOWED TO FLOAT AS DESIGNED. ASSURE THAT THE TERMINALS ARE CRIMPED PROPERLY BY USING ONLY MOLEX TERMINALS AND PROPERLY MAINTAINED MOLEX AUTHORIZED APPLICATION TOOLING.
7. FOR PROPER MATING OF SHROUDS, THE POD LOCKING FINGERS ON BOTH SHROUDS MUST BE ORIENTED SUCH THAT THEY ARE ON THE SAME PLANE WHEN MATING THE CONNECTORS. THE SIDE LATCHES OF THE SHROUD ARE DESIGNED TO PROVIDE POLARIZATION.
8. EACH SHROUD POD BAY IS KEYS TO PROVIDE POLARIZATION. THE POD MUST BE INSTALLED IN THE DIRECTION SHOWN WHEN INSERTING A POD INTO THE SHROUD. THE 'U' SHAPED FEATURE ON THE SIDE OF THE POD MUST BE ORIENTED TO THE SAME FACE AS THE POD LOCKING FINGERS ON THE SHROUD.
9. AS THE 'FACE TO FACE' MATING OF THE PODS IS CRITICAL TO ASSURE THAT ALL CONTACTS ARE FULLY 'WIPE'D', THE TOLERANCES OF THE SHROUD TO SHROUD MATING ARE TIGHTLY CONTROLLED. THEREFORE, WHEN SEATING A POD INTO A SHROUD, MAKE CERTAIN THAT THE SHROUD LOCKING FINGER IS FULLY SEATED INTO THE POD. IT MAY BE NECESSARY AT TIMES TO APPLY A SLIGHT VERTICAL FORCE TO THE LOCKING FINGER TO SEAT THE POD FULLY. ALSO, WHEN MATING TWO SHROUDS, ASSURE THAT THE SHROUD POSITIVE LOCKS, LOCATED ON THE SIDES OF THE SHROUD, ARE FULLY ENGAGED WITH THE MATING SHROUD.
10. PODS MAY BE REMOVED FROM SHROUDS IF REQUIRED. TO REMOVE A POD, SIMPLY DEFLECT THE LOCKING FINGER AWAY FROM THE POD, USING A FINGER NAIL OR A SMALL STRAIGHT BLADE SCREWDRIVER, JUST FAR ENOUGH TO DISENGAGE THE POD. CAUTION: EXCESSIVE DEFLECTION MAY DAMAGE OR DESTROY THE LOCKING FINGER.
11. THE SHROUD PROVIDES SYSTEM POLARIZATION. PODS MUST NEVER BE APPLIED WITHOUT THE USE OF A SHROUD.
12. MATED CONNECTOR ASSEMBLIES MUST BE UNMATED WITH A STRAIGHT PULL IN THE DIRECTION SHOWN. TO PREVENT DAMAGE, AVOID ROTATING THE ASSEMBLY DURING UNMATING.

INSERT PODS IN THIS DIRECTION UNTIL FULLY LATCHED IN SHROUD. SEE APPLICATION NOTES 8 & 9

PODS ARE KEYS TO PREVENT IMPROPER ASSEMBLY.

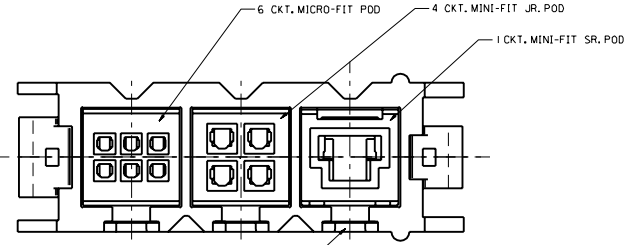
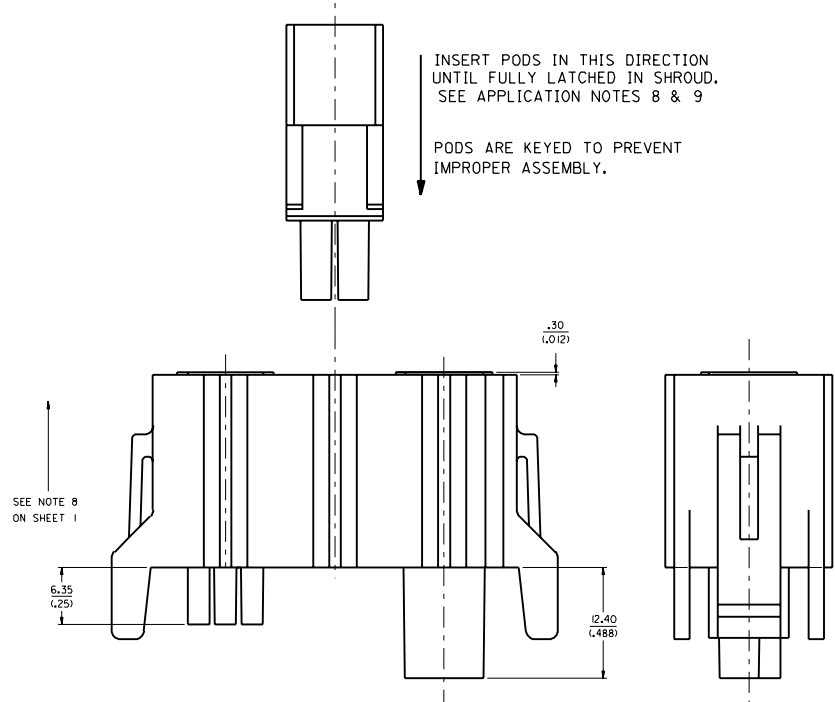

CAUTION: SEE APPLICATION NOTE 10

ADD APPLIC. NOTE 10 EC NO. UCR1999-0712 DRW/POL/GAR 99/04/22 CHK: COMERC1 99/04/26 APPR: COMERC1 99/04/26	QUALITY SYMBOLS MAJOR ∇ 0 CRITICAL ∇ 0	GENERAL TOLERANCES: (UNLESS SPECIFIED) mm INCH 4 PLACES ± 0.15 $\pm .006$ 3 PLACES ± 0.25 $\pm .010$ 2 PLACES ± 0.38 $\pm .015$ 1 PLACE ± 0.51 $\pm .020$	SCALE 4 : 1 DESIGN UNITS <input checked="" type="checkbox"/> mm <input type="checkbox"/> INCH	DESIGN BY & DATE COMERC1 97/10/07 CHECKED BY & DATE COMERC1 97/10/07 APPROVED BY & DATE FRY 97/10/10	DIMENSIONS: mm <input checked="" type="checkbox"/> INCH <input type="checkbox"/> mm ONLY	SHT REV REVISE ON CAD ONLY
	THIRD ANGLE PROJECTION	TITLE: RECEPTACLE SHROUD, 12.3 mm/(.484) PITCH, COMPODRE SYSTEM	MOLEX INCORPORATED	CAD FILENAME: S4383804.DGN MATERIAL NO.: SEE CHART DRAWING NO.: SD-43838-002	SHEET NO.: 2 SIZE: D	